

Masthead - requires 2 sheaves for halyard and topping lift.  
Wiring tube runs to masthead

Spinnaker Halyard sheave box  
Gibb T Bar Plate for 1/4" wire

Min. 1/2" thick Al.  
Tab with 17/32" hole  
for forestay toggle

Steaming and  
Deck light

Gibb T Bar Plate for 1/4" wire  
Spinn. Pole topping  
lift sheave box

Gibb T  
Bar Plate  
for 1/4"  
wire

Spreaders: 23.5"  
long, raked aft 25°,  
and up 5°

Gibb T Bar Plate  
for 1/4" wire

Spinnaker Pole ring  
Boom

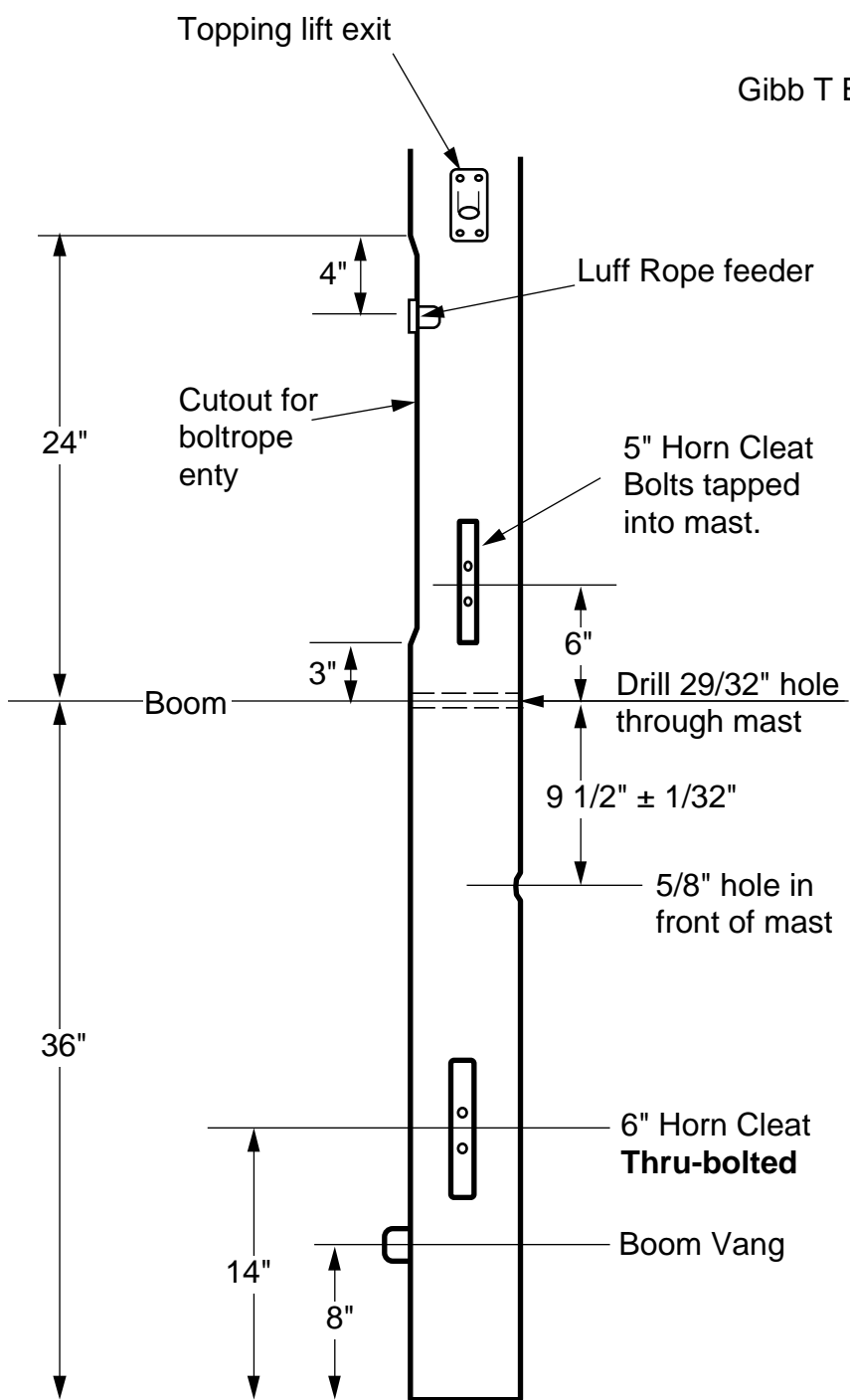

**MAST BASE**

Wiring tube must clear Boom hole

Mast to be Anodized Black or Clear

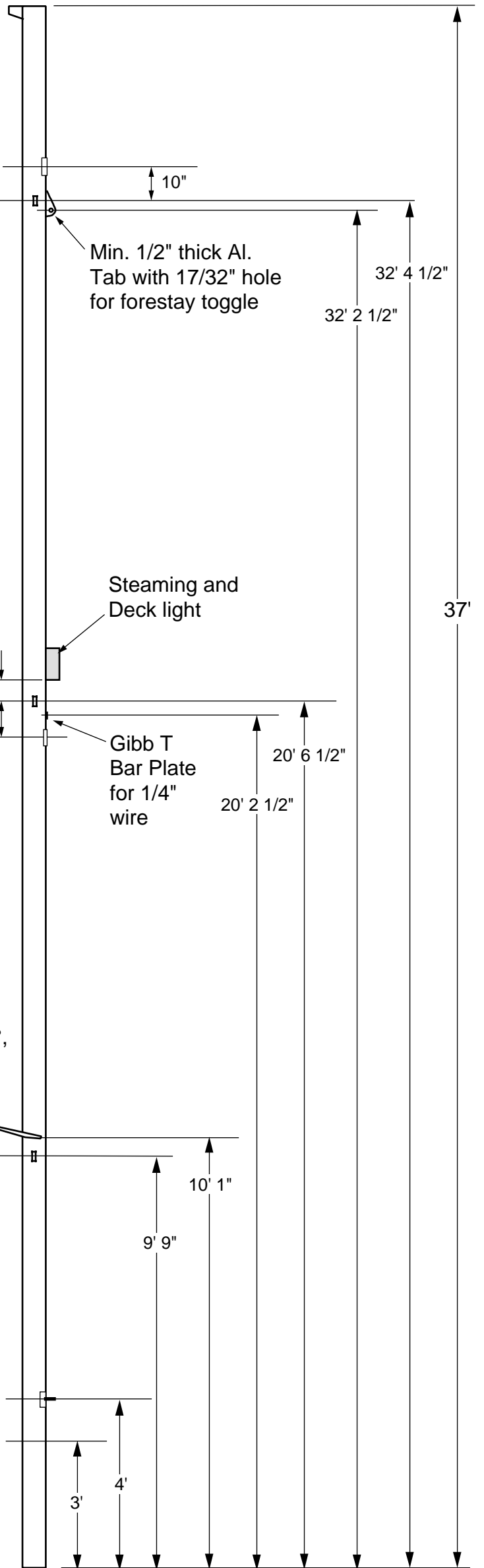

**Mast Section:**

Approx. 3.6" x 5.6" x 37' long  
Min. lxx = 2.9 Min. lyy = 7.3  
Approx. weight 2.2lbs/ft.

**F-27 MAST DETAILS**

**CORSAIR MARINE**, 150 Center St.,  
Chula Vista, CA 92011. Ph. (619) 585 3005

Scale 36:1

Drawn by Ian Farrier May 4, 1990